

# PERI UP Flex Working Platforms

Safe and flexible solutions for industrial applications



# Content

## **System Advantages**

- 4 PERI UP Flex Working Platforms
- 6 High level of working safety
- 8 Offset and trip-free working areas
- 10 Fast assembly
- 12 Cost-effectively combined with VARIOKIT steel components

## **System Overview**

- 14 Flexibly adapted to suit different geometries

## **Standard Applications**

- 16 Bracket solutions for widening working levels
- 17 Large working platforms with spans of up to 10 m
- 18 Fast scaffolding of circular structures using only system components
- 19 Small and light components for assembly in confined spaces or manholes
- 20 Solutions for movable working platforms and suspended scaffolding

## **System Supplements**

- 22 Stair tower for accommodating high load requirements and accessibility

**Issue 04/2019**

### **Publisher**

**PERI GmbH**  
**Formwork Scaffolding Engineering**  
Rudolf-Diesel-Strasse 19  
89264 Weissenhorn  
Germany  
info@peri.com  
www.peri.com

### **Engineering and Services**

- 24 PERI services for the best results
- 26 Scaffolding and engineering from one source
- 28 Reliable partner for scaffolding technology in the industrial sector
- 30 Safety throughout the product life cycle

### **Project Examples**

- 32 PERI UP Flex Working Platforms in use

#### **Important Information**

All current safety regulations and guidelines applicable in those countries where our products are used must be observed.

The images shown in this brochure feature construction sites in progress. For this reason, safety and anchor details in particular cannot always be considered conclusive or final. These are subject to the risk assessment carried out by the contractor.

In addition, computer graphics are used which are to be understood as system representations. To ensure a better understanding, these and the detailed illustrations shown have been partially

reduced to show certain aspects. The safety installations which have possibly not been shown in these detailed descriptions must nevertheless still be available. The systems or items shown might not be available in every country.

Safety instructions and load specifications are to be strictly observed at all times. Separate structural calculations are required for any deviations from the standard design data.

The information contained herein is subject to technical changes in the interests of progress. Errors and typographical mistakes reserved.



# PERI UP Flex Working Platforms

**With the PERI UP Flex scaffolding system, a wide range of working platforms can be realised. The system is characterised by a high level of safety during assembly operations and during use; with comprehensive side protection and closed, non-slip surfaces, it meets the high demands placed on occupational safety in industrial applications.**

The PERI UP Flex scaffolding system has been optimised to ensure a high level of flexibility during use. For this, all components of the system are based on a consistent metric length and width grid arrangement of 25 cm. This allows any directional change of the decking to take place within the scaffold bays. Thereby, simple modifications can be made to accommodate any obstructions, and working areas and platforms can be closed virtually gap-free – without height off-sets or tripping hazards. In addition, the slip-resistant decks, end-to-end guardrails and toeboards provide a high level of safety during use. Furthermore, PERI UP Flex can be mounted with the guardrail in advance.

Constructive detail solutions such as the self-locking ledger connection and the integrated protection against lifting make it easy to assemble the system quickly and with virtually no tools. The lightweight design of the system components also facilitates fast assembly and is therefore very cost-effective. Tension-proof connections also make it possible to move large scaffold units by crane – yet another contribution to accelerating assembly and working times.

With a wide range of supplementary system components and accessories, PERI UP Flex can be used to realise working platforms for multiple applications – with virtually no time-consuming tube couplers.

- **High level of working safety**
- **Offset and trip-free working areas**
- **Fast assembly**
- **Cost-effectively combined with VARIOKIT steel components**

## High level of working safety



**With a complete and end-to-end side protection consisting of two guardrails and toeboards on all sides as well as non-slip decking, PERI UP Flex working platforms fulfil high safety requirements. These system-integrated user safety measures reduce accident and injury risks and create safe and secure work places.**

Continuous guardrails and toeboards between the standards provide a visible border on the working scaffolds and platforms on all sides; for use around corners, simply turn one of the toeboards. The risk of any materials or small objects falling to the ground is thereby counteracted.

Toeboards are non-flammable and highly visible due to the signal colour. As a result, this makes it easy to check their completeness from a distance.

Due to the perforations, the steel decking is also suitable for utilisation in those areas of use where slip resistance has the highest priority.

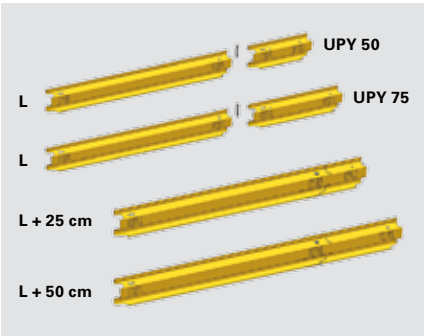

The perforated decking ensures that the steel decking is extremely slip-resistant and reduces ice formation in winter.

In order to completely close the intermediate lengths, shorter toeboards can be screwed to longer toeboards.



Well-thought-out details and system-integrated user safety facilitate cost-effective and safe working operations.



PERI UP Flex Stairs with closed decking areas can be flexibly integrated into the scaffolding solution to ensure safe access.

## Offset and trip-free working areas

**Complex scaffolding tasks are quickly and easily realised with PERI UP Flex. Due to the integrated system grid arrangement of 25 cm, obstructions such as pipelines or load-bearing constructions can easily be accommodated and working areas covered virtually gap-free and without any height offsets in the decking.**

The mounting direction of the decking can be changed within an individual bay of four load-bearing verticals at any point in the 25-cm grid – also several times if required.

Due to the rectangular shape, the top edges of the ledgers are always at the same height, and the decking forms closed, level and trip-proof working platforms without any height offsets.



The change in direction of the decking in the 25-cm grid provides an enormous adaptability – and without any tube couplers.

By the mounting the ledger between the decks, each bay can be sub-divided. Column or pipe outlets can be flexibly accommodated.



The large degree of flexibility provided by the change in direction of the decks is a great advantage especially in complex industrial plants.





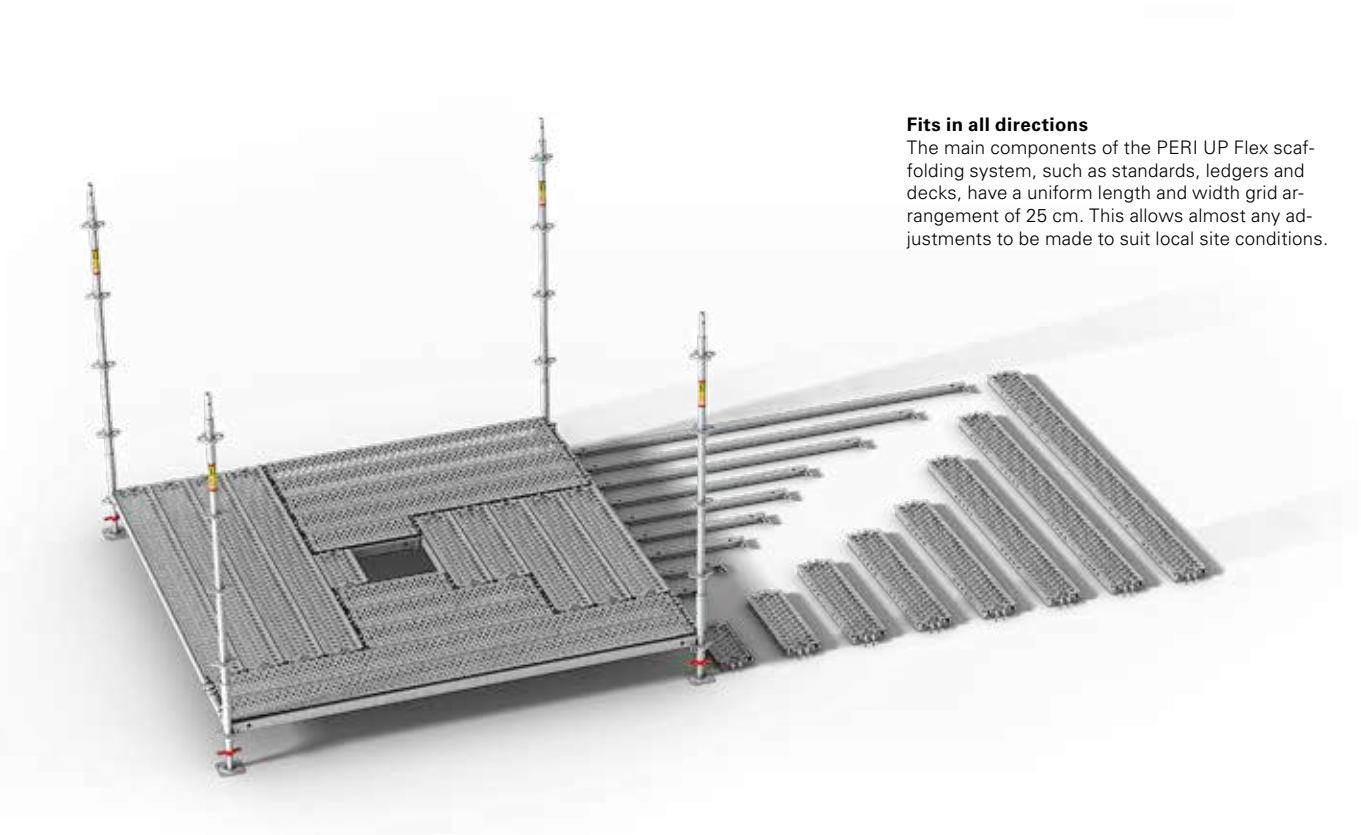

**Fits in all directions**

The main components of the PERI UP Flex scaffolding system, such as standards, ledgers and decks, have a uniform length and width grid arrangement of 25 cm. This allows almost any adjustments to be made to suit local site conditions.

Connections for ledgers and standards for any sub-division of the scaffolding bays

**Ledger-to-ledger connection:**  
Ledger to Ledger Couplers with one or two connecting possibilities.

**Standard-to-ledger connection:**  
Spigot with one or no ledger connection.



## Fast assembly

**Special design details such as the ledger with Gravity Lock and the self-locking deck (Locking Deck) facilitate easy and safe assembly. With a focus on lightness, the low weight of the system components also allows quick and cost-effective installation.**

The ledgers fulfil a range of functions. This reduces component diversity and simplifies assembly operations. In addition to being used as guardrails, the same ledgers serve as support for the decking at the level of the platform.

Assembly of the ledger takes place without any couplers. As a result, it can be mounted very quickly in just a few simple steps.



Workplaces for installation and maintenance work are quickly realised with PERI UP Flex. Pipelines can be easily accommodated and decking only installed where it is actually required.



Due to the low weight and special design, the toeboard can be conveniently stacked and transported by hand.



**Gravity Lock**  
**Fast and almost tool-free ledger assembly**

PERI UP ledgers have a connection in the form of a wedge, which is hooked into the rosette opening. Thereby, the securing wedge drops into the rosette nodes due to its own weight and locks automatically. This ensures that on-site assembly is easy and safe. The wedge is then secured in position with one blow of a hammer.

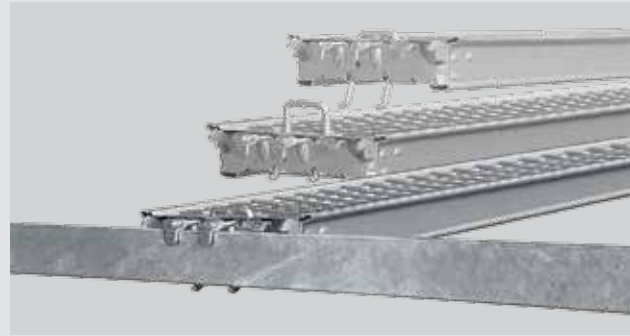

**Locking Deck**  
**Simple and tool-free decking installation without any additional protection against lifting**

The integrated clamp engages the rectangular ledger, securing the position of the decking. PERI UP decks are also secured against lifting after installation without requiring any additional components. Individual scaffold bays can subsequently be removed if required, e.g. for bringing in materials.

## Cost-effectively combined with VARIOKIT steel components



**If special constructions are required in the context of project-specific solutions, the scaffold system can be complemented with rentable steel components taken from the VARIOKIT Engineering Construction Kit to form a safe and economical PERI system solution.**

Due to the almost unlimited combinability of PERI UP with standardised, rentable VARIOKIT system components, supporting structures and bridging can be realised very cost-effectively. Both systems follow a uniform metric basic grid arrangement. This allows the working platform to be geometrically and statically adapted to suit the industrial facility.

Thanks to the uniform 25 and 12.5-cm system grid of the VARIOKIT Engineer-

ing Construction Kit, steel components can be ideally combined with PERI UP. Standardised connectors result in almost seamless assembly operations - without time-consuming tube-coupler assemblies.

Through the worldwide PERI rental park network, solutions are not least extremely cost-effective because the standardised system components can be rented according to project-specific requirements each time.



Both systems can be combined due to the uniform 25 or 12.5-cm grid arrangement.



## Flexibly adapted to suit different geometries





The PERI UP Rosett nodes allow for connections up to 45°.



The node area offers 12 connection possibilities. In addition to four Ledgers and Node Braces respectively, four Ledger Braces can be connected.

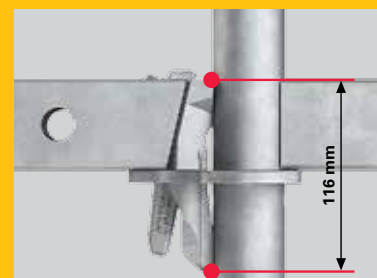

The wide contact point spacing of the ledger head on the Standard results in a high level of flexural strength in the connection area and optimises the load-bearing capacity.

## Bracket solutions for widening working levels

**With the bracket solutions, working levels can be widened and adapted to accommodate different geometries.**

With different widths from 0.25 m to 1.00 m, different geometries can be reconfigured.

By means of other system solutions, e.g. node braces with ledgers, cantilevers up to 3.00 m wide can be realised.





## Large working platforms with spans of up to 10 m

**Working platforms with large spans can be realised according to the respective load using different system components.**

Reinforced ledgers can carry a higher load compared to standard ledgers. Depending on the span, a chess-board-type arrangement of the decking is not required.

Through combined use with PERI UP Flex standards and decking, cost-effective bridging from 3.00 m to 10.00 m in 25-cm increments can be realised with lattice girders.

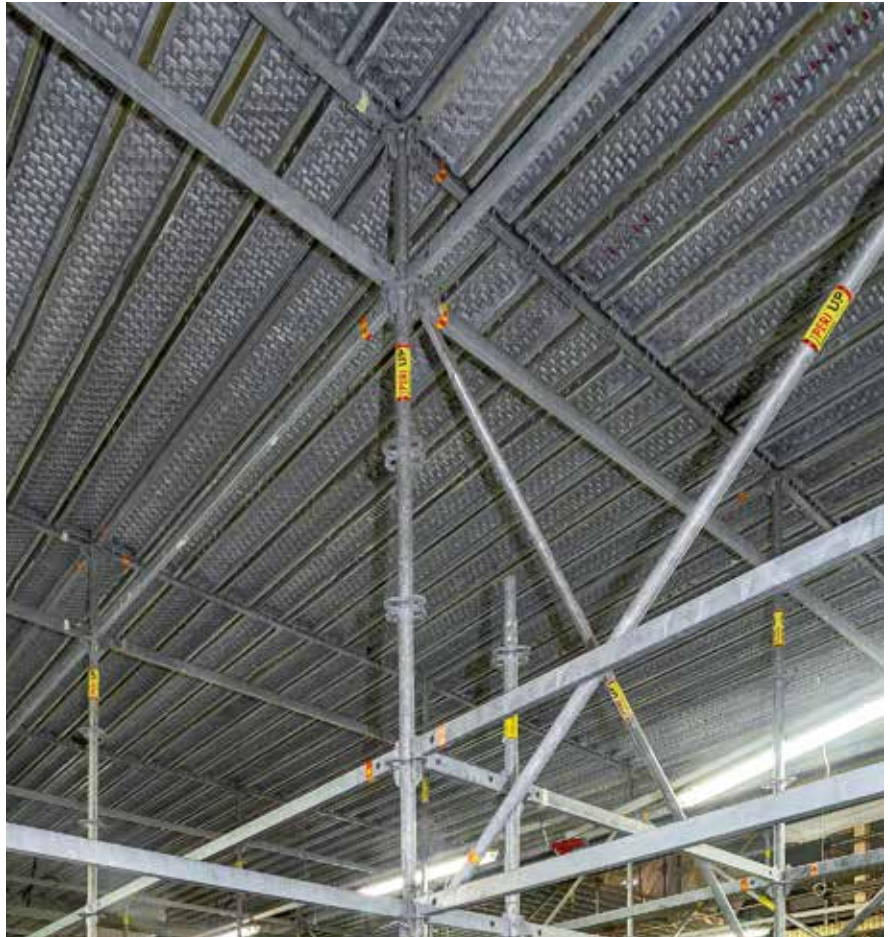

### Reinforced ledgers

Each ledger length can be completely covered with system decking, and gaps do not need to be covered.



### Lattice girder

Lattice girders can be easily and quickly mounted on the connecting element by means of bolts and cotter pins, and attached to the rosettes of the PERI UP standards – without any tube and coupler connections

## Fast scaffolding of circular structures using only system components

**With some scaffold systems, scaffolding circular structures such as tanks and containers often requires the use of tubes and couplers. With PERI UP Flex and the PERI cover plate, the entire installation can be carried out using only system components. This facilitates reduced assembly times.**

The scaffold bays are arranged polygonally and connected to form a ring to adapt to the radii of the circular structures. On the outer side of the scaffold, the side protection, consisting of guardrails and toeboards, is integrated in the system grid. A ledger is connected transversely with the help of a ledger support to support the decks.

Gaps in the decking of the rotated scaffold bays can be closed with cover plates. They are securely fixed to the ledgers.

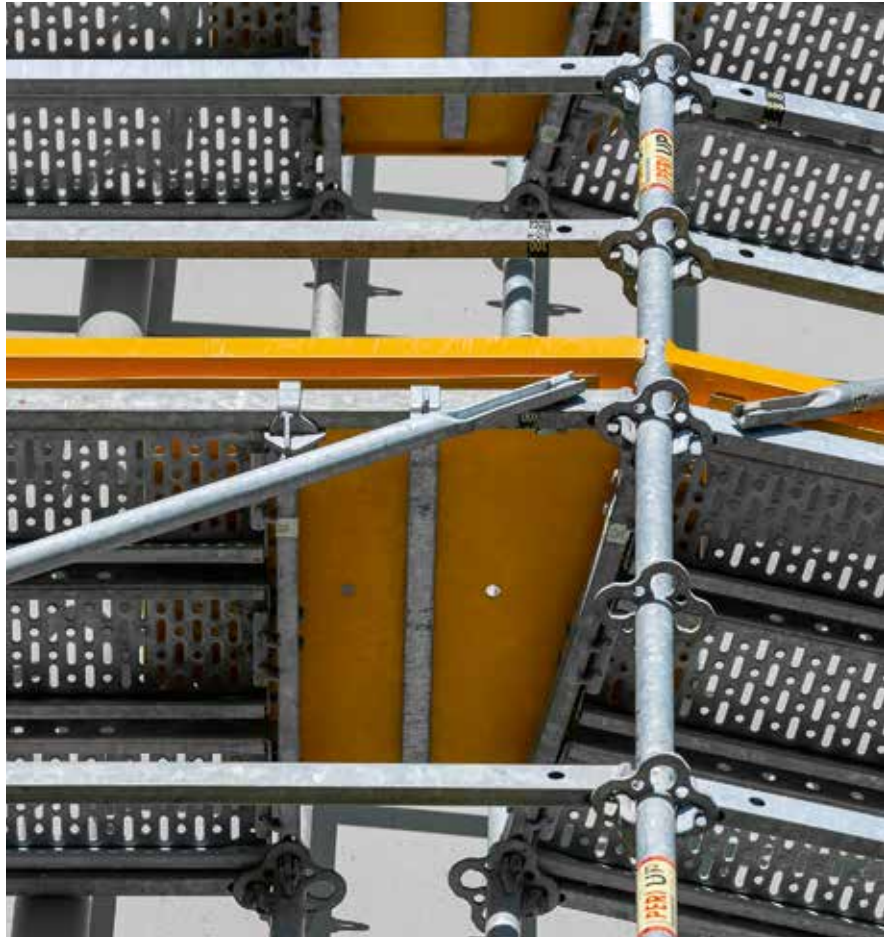

One cover plate is sufficient to cover the gaps in the decking of the rotated scaffold bays irrespective of the diameter of the circular structures.

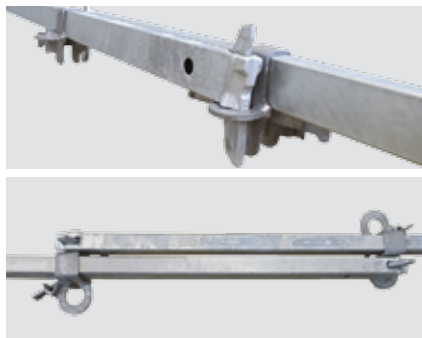

For easy positioning of the inner guardrail, the ledgers with the ledger support are telescopic.



For gap-free scaffold installation of circular plant construction components with small diameters, the corner plate can also be used.

## Small and light components for assembly in confined spaces or manholes

**Small and lightweight system components facilitate scaffold assembly in confined spaces or material transport with difficult access and narrow elevators.**

All PERI UP Flex system components, such as standards, ledgers and decks, follow a length grid arrangement of 25 cm or height increments of 50 cm. The small and lightweight scaffolding components can be easily passed through small openings due to the practical formats or comfortably mounted in tight spaces.

The PERI UP Flex Staircase 100 / 125 can also be easily passed through tight openings thanks to the small components.

If hatches are used inside containers, often only small manholes (approx. 55 cm or 22 inches) are available for material transport. In bays with small bay lengths, hatches with the widths of 50 cm and 75 cm can likewise be installed. They consist of a frame with access opening and short decking piece as well as an attached ladder.

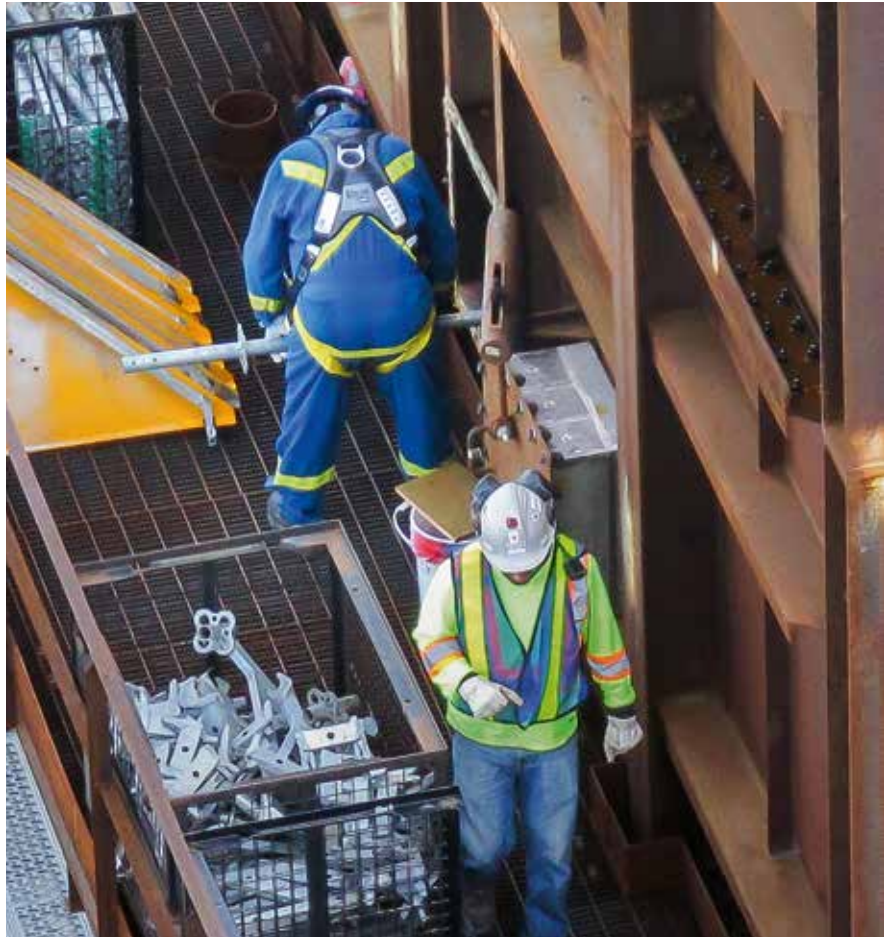

The hatch flaps can also be opened in the event of circumferential toeboards.

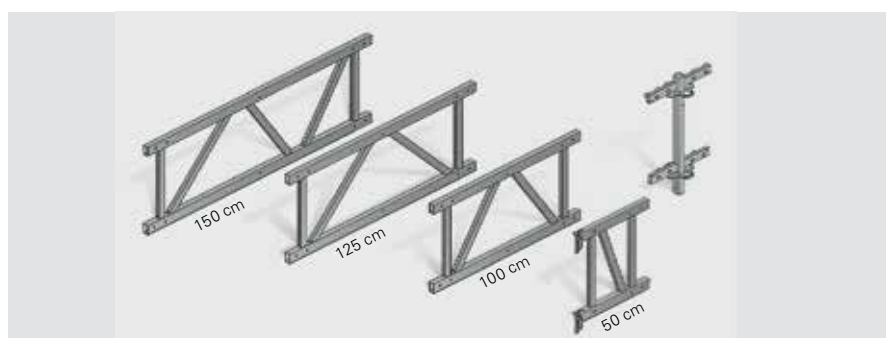

Due to the compact dimensions with individual lengths of 50 cm to 150 cm and a support height of 50 cm as well as the low weights – maximum 15.4 kg – the PERI UP Flex lattice girders can also be used in confined spaces and when accessing manholes.

## Solutions for movable working platforms and suspended scaffolding

**For roller-guided solutions, the standards and the trolley can be suspended or placed on I-shaped steel profiles. The trolley carries loads of up to 19.7 kN and allows entire platforms to be moved, e.g. on the underside of oil platforms.**

Due to the practical design, the trolley can be used on various steel profiles. It can be adapted to suit girders of 20 cm to 32 cm wide with flange thicknesses up to 40 mm. Thanks to the variable adjustment of the mounting for the standards independent of the flange width, construction in the system grid is possible.



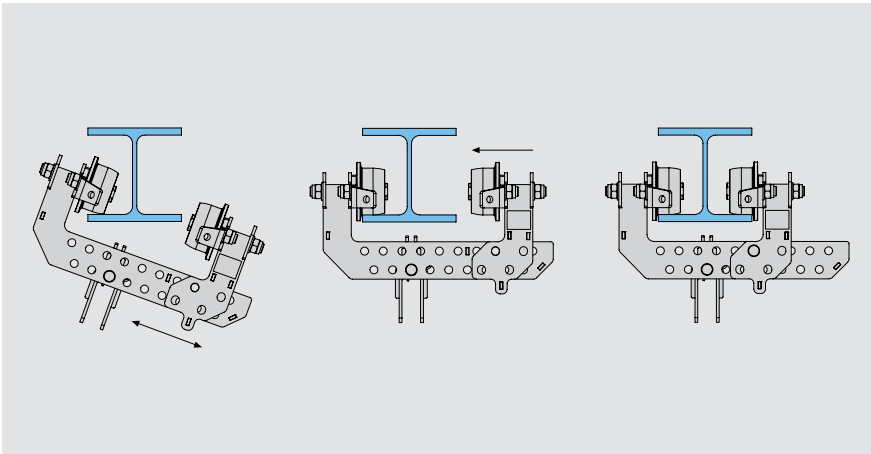

**Solution for suspended working platforms when moving with the trolley**

One of the roller holder legs can be moved for installation. The roller spacing can be adapted to accommodate the steel girder and is secured by means of a bolt.



**Solution for movable working scaffold**

Through smooth-running rollers as a system component, the scaffold can easily be moved.



**Solution for rigidly suspended scaffolding**

For cost-effective realisation of project-specific solutions, rentable steel components taken from the VARIOKIT Engineering Construction Kit can be used for the load-bearing construction.

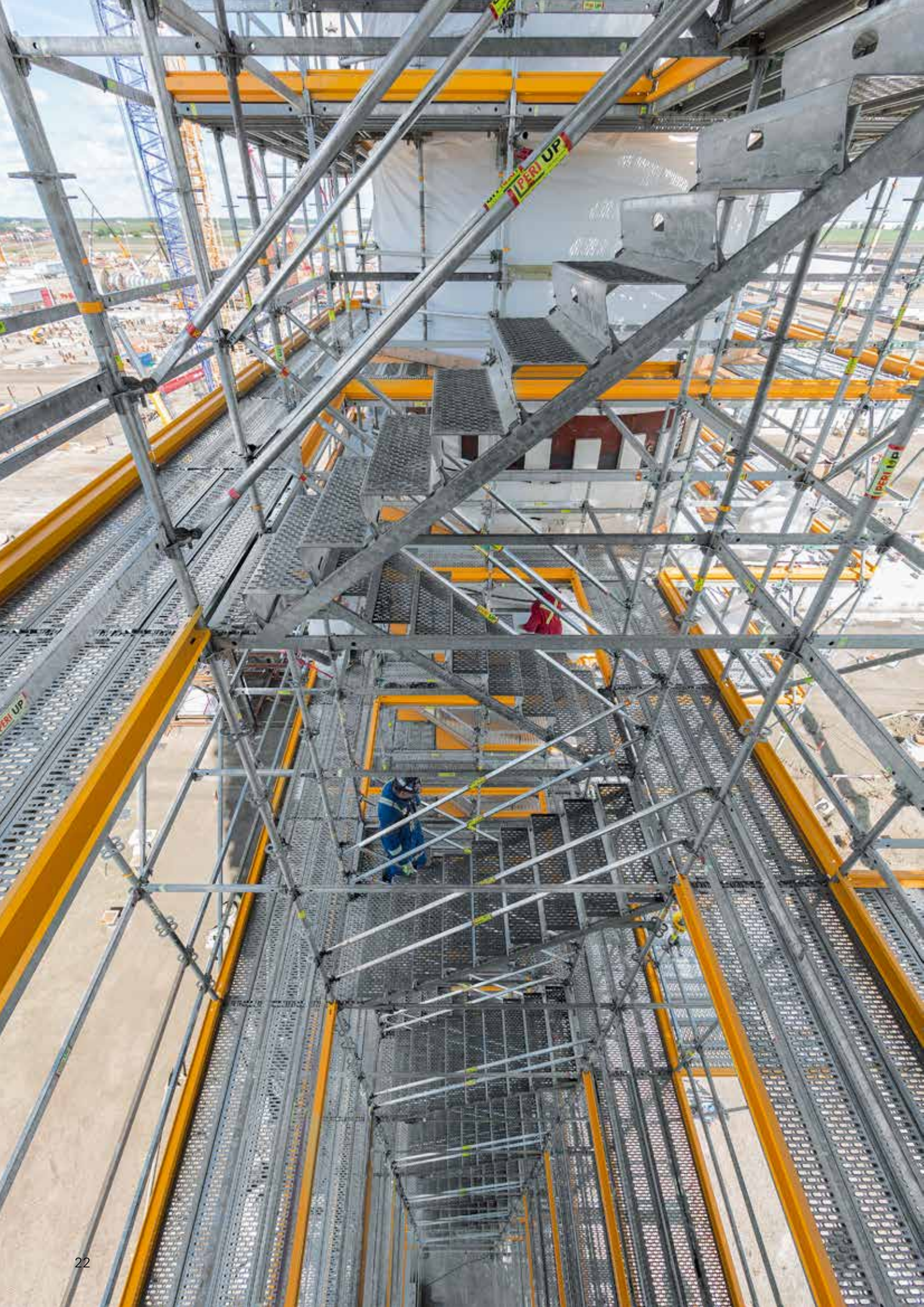

## Stair tower for accommodating high load requirements and accessibility

**The PERI UP Flex Staircase 100 / 125 can be used as staircase units in the same direction or alternating staircase units with assembly heights of 2.00 m to 50.00 m. They can be erected as stair towers or staircases around a stair well.**

With a step width of 100 cm or 125 cm and separate landings, the stair tower provides convenient and easy access also when wearing working clothes and with suitable protective equipment – site personnel can comfortably pass each other as the staircase offers sufficient space. The maximum live load of a tower is 40 kN. This makes the staircase ideal for higher user volumes and it can be used by up to 50 people at the same time.

In addition to a safe transfer of loads, slip resistance is an important requirement for all stairs. The steps as well as the scaffold decking are therefore per-

forated and are safely accessible even with oil-smearred shoes. At the same time, the perforation makes the formation of ice more difficult in winter as hardly any water can accumulate and freeze. Due to the closed design of the steps, small objects are prevented from falling through.

Assembly of the stair steps is easy and fast without requiring any tools: the stringers are mounted first followed by the individual steps which securely interlock during installation without the use of additional components. The top step secures all the others.



Stair towers with alternating staircase units provide greater head clearance and shorter walking distances for site personnel between levels.



Stair towers with staircase units in the same direction have the advantage that, in addition to staircase units, working levels are also available.



## PERI services for the best results







**PERI customers can rely on a comprehensive range of engineering and service solutions.**

The focus of all PERI activities is on having a collaborative partnership with customers and ensuring that we provide cost-effective project solutions – consistent, close cooperation throughout the entire project is a matter of course to us.

With the Integrated Scaffolding Program (ISP), we offer our industrial customers a range of services that help them ensure successful completion of their project.

## Scaffolding and engineering from one source



**On the one hand, our company's focus is the development and manufacture of formwork and scaffolding systems which make working on the construction site faster and safer. On the other, we consider ourselves a source of ideas and a supporter, enabling us to develop the best possible solution with our customers in each case to meet individual requirements.**

Because we know our customers, their tough daily working conditions and their competition, it is basically always about our products and services simplifying and accelerating work operations, improving safety and in particular helping to reduce both the time and costs involved. PERI products are therefore designed so that they provide users and construction companies with advantages in terms of handling, workload reductions, enhanced safety, as well as cost and personnel savings.

For our supplementary range of services, we always have our customers' business, their benefits and resulting added value in focus. A PERI solution is always the result of three factors combined: product, work preparation and execution. With our vast experience from global projects, we support our customers throughout all project phases – from the drawing up of feasibility studies for particularly challenging projects, formwork and scaffolding planning through to provision of contin-

uous support during the entire project. Our system equipment is available in more than 120 rental parks strategically located around the world, and thus we provide our customers with a cost-effective option for peak demands or specific project tasks.

To this end, our company goal is ensuring customer satisfaction. Our entire business operations are focused on achieving this, which results in our strict insistence on achieving maximum customer benefits. We want our customers to profit directly from PERI products as well as the close collaboration with us and have a real competitive edge in the market – both technically and economically.

The partnership with our customers provides an advantage regarding additional market opportunities, flexibility and competitiveness in order to sustainably and positively influence their business development.



Over 1,300 PERI engineers worldwide are hard at work every day in order to develop efficient solutions and practical implementation plans to realise our customers' projects.



For us, training seminars and courses on PERI products are an important aspect of our services with added value: users thus learn to use the systems on the construction site efficiently from the very beginning.



Individual PERI project management on site or the professional site briefings provided by our very experienced supervisors increase cost-effectiveness during execution.

**In product development, PERI engineers not only place the highest priority on the integrated safety in the system and a reduced number of components. The focus is likewise always on simple and practical product logistics. The PERI UP scaffolding system therefore provides further economic advantages through the numerous practical details and supports ergonomic and safe working operations.**

Through the special design of the rosette, PERI standards do not roll away and are easy to stack. As a result, this allows several standards to be comfortably carried on the stairs. They do not slip and one hand is free to hold onto the guardrail.

PERI decks can also be stacked to save space with little effort. Due to the well-thought-out design, the decks interlock with each other just like the standards.

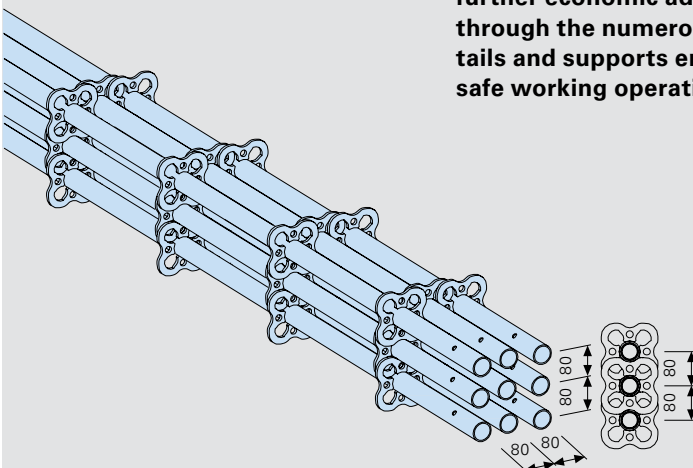

## Reliable partner for scaffolding technology in the industrial sector

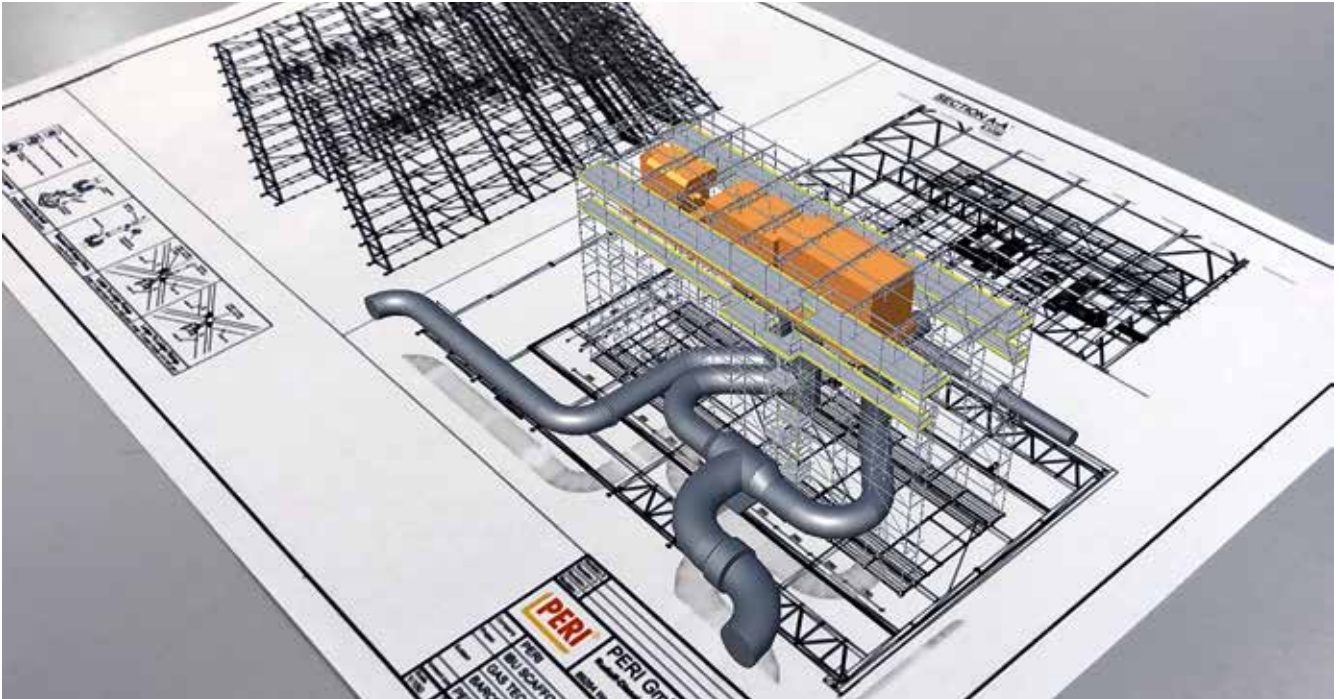

**The Integrated Scaffolding Program (ISP) from PERI offers industrial customers from a wide range of segments a comprehensive scaffolding solution. In addition to the PERI UP industrial scaffolding, customers are offered services that support them in the execution of the individual projects.**

Developed by industry experts, the ISP aims to make relevant but previously neglected cost blocks transparent. With the ISP and the integration of scaffolding into the overall planning, the customer is provided with control instruments that enable him to intervene in ongoing processes before the budget is exceeded: this means in-

creased planning capability, reduced inventory costs and increased efficiency.



## Increased planning capability

### Scanning

Through the use of scanner technologies, accurate 3D models are created which integrate the scaffolding planning. This results in considerable time savings especially on projects relating to maintenance and servicing, as there are often only insufficient plans of existing inventory available.

### Design and optimisation

Through the consistent integration of 3D scaffolding planning into the overall project plan and the allocation of the respective activities, both the material requirements as well as required work performance can be optimised.

### Quality assurance and quality commitment

As the manufacturer of PERI UP, PERI is subject to the obligations and requirements of various certification and testing bodies. Not only the external monitoring but also the high self-requirements in terms of keeping promises made to our customers lead to production processes and product design meeting the highest safety and quality requirements.

## Reduced inventory costs

### PERIpath

With the help of the 5D software, PERIpath, the entire project is presented from the planning phase through to the end of the project. PERIpath allows the customer to plan the scaffolding, follow its assembly and manage dismantling operations including re-use. Through a clear reporting portal, the demand and use of materials and labour become visible. After completing a project, the data is saved and can be used as reference values for the next project.

## Increased efficiency

### Program management

A PERI program manager supports the customer on site to ensure the correct application of the ISP.

### Training

PERI offers product and software training (PERIpath and PERI CAD). This can take place on site or at the PERI training centre.

### Cooperation partners

PERI has a worldwide network of cooperation partners who can assemble and dismantle PERI UP for customers.

## Safety throughout the product life cycle

**Not only with the PERI UP modular scaffolding kit has PERI demonstrated that safety does not preclude cost-effectiveness in any way. We follow the principle that the best solution for the customer must always be one of the safest.**

At the same time, PERI understands the issue of safety in a processual sense, whereby PERI engineering and scaffolding technology is integrated into the customer's project in a timely and targeted manner.

A functioning safety concept covers all aspects of the entire product life cycle. It has to be fully integrated – therefore, we also take into consideration topics such as legal certainty and future viabil-

ity. Binding offers and clearly regulated criteria for rental and return of materials also offer you security. Many items can also be rented on a project-related basis. Take advantage of our simple work preparation procedure and execution control using our PERI software for scaffolding planning. Standardised parts lists, easy and quick ordering options and return deliveries allow optimised personnel deployment and material usage.



### Employee protection

Lightweight individual components for fatigue-free working, integrated user safety and an easily understandable system with design-related logical assembly sequences ensure a high level of employee satisfaction.



### Legal certainty

PERI provides complete and comprehensive documentation, taking into consideration all current standards, requirements and regulations. In addition, this serves as a basis for customer-specific construction site documentation such as assembly instructions and risk assessment.



### Quality

State-of-the-art production and inspection processes are the reason that PERI systems are subsequently suitable for tough everyday operations on the jobsite and can be used reliably. The entire process of the serial production that follows is subject to continuous quality assurance.

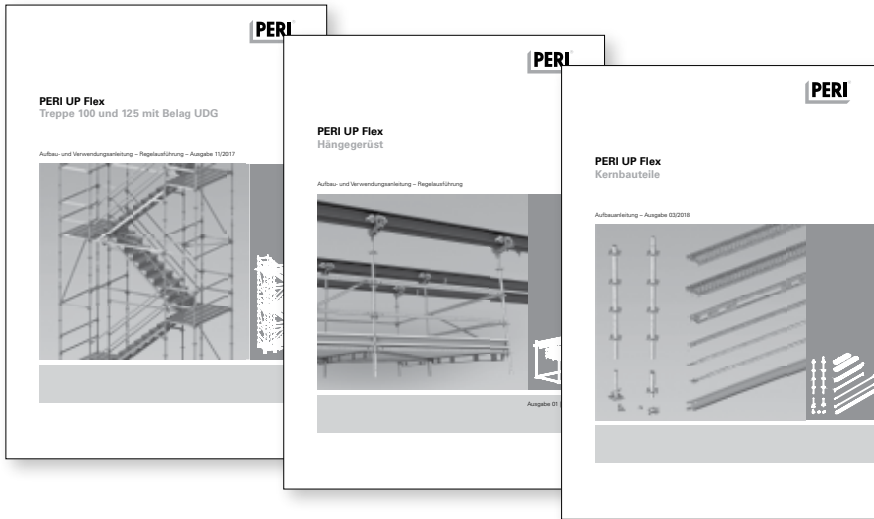

Smooth construction process: with the latest material technology, approvals and type tests as well as a comprehensive range of services, PERI makes a significant contribution by supporting customers on site in carrying out successful construction projects. Risk as-

sessments and assembly instructions can be created easily with the support and documentation provided. Instructions for Assembly and Use are the basis for a cost-effective and safe working practice. PERI offers a high level of safety during assembly by providing

the Instructions for Assembly and Use in different languages. The depictions of individual assembly steps and the complete structure are simple and easy to understand.



German Institute of Building technology (DiBt)



German Standardisation Institute (DIN)



Association française de normalisation (NF ANFOR)



Poland Approval: B-Symbol



Research Institutes of Sweden (SP)

## PERI UP Flex Working Platforms in use







**The following pages feature project references which provide an overview of the different application areas.**

## PERI UP Flex working platforms in use



### **New Construction of an Acetylene Plant, BASF** Ludwigshafen, Germany

With a capacity of 90,000 t per year, the plant has replaced an older, less-productive facility and operates in accordance with the world's most efficient production processes. Acetylene is an important intermediate product and is used as a central source material for around 20 production plants at BASF's Ludwigshafen site.

It is not just the new plant that works with the world's most modern technical facilities and processes. During the construction, modern planning and working methods were also used – this formed the basis for assembly work operations remaining on schedule. Up to 1,300 people were working at peak

times on the jobsite, which covered an area of around 55,000 m<sup>2</sup> – the equivalent of almost eight football pitches – and had an installation height of up to 90 m.

In order to install the plant technology efficiently and safely, which featured more than 400 machines and pieces of equipment along with a 90-km-long pipe system and electrical installations, the PERI UP Flex Modular Scaffolding System was used in the second construction phase. New working levels and access means were realised for construction and assembly work on an almost daily basis.

The central project approach was based on the combination of BIM methodology for the planning and execution, and high standards of work safety. The jointly developed, innovative scaffolding concept provided the basis for a comprehensive overall solution for efficient scaffolding construction management, 3D planning, cross-trade coordination and execution, in order to minimise planning time and costs. With its 25-cm grid in combination with VARIOKIT system components, PERI UP Flex thereby ensured excellent adaptability and occupational safety at a very high level.



## Gulf Coast Petrochemicals Project, Baytown, Texas, USA

High degree of safety and enhanced efficiency

Just considering the sheer size of the \$5 billion ethane cracker at Chevron Phillips Chemical, with a targeted production output of 1.5 million tonnes, is extremely impressive. The complexity of the facility is also highlighted when looking at the amount of steel that has been installed along with the continuously winding pipelines. For the construction, it was necessary to provide workers with secure access means at all points. On the one hand, this required an enormous amount of scaffolding materials. On the other, it is important for projects of this size that all relevant information regarding the scaffolding components is constantly available.

The Integrated Scaffold Program (ISP) from PERI encompasses the 5D PERI Path software program and facilitates early cost estimates, operational planning and materials management as well as planning on-site material requirements in advance. In Baytown, the software monitored the use of around 750,000 scaffolding components and all related work considerations. The data allowed a detailed analysis of the working hours to be carried out and provided enormous transparency. As a result, it was possible to plan in more detail, reduce labour and logistics costs, and more effectively manage scaffolding operations.

The PERI UP Flex scaffolding system used was able to accurately follow the numerous cylindrical reactors and countless pipelines as well as providing the highest level of safety for all site personnel throughout the entire construction process.

## PERI UP Flex working platforms in use



### **Biocel Pulp Mill, Paskov, Czech Republic**

Systematic adaptation for completely safe working conditions

The pulp mill in the Czech town of Paskov has expanded and modernised its production facilities. The special pulp produced here is an important raw material for further processing into high-quality cellulose fibre products. For this, five 13-m-high circular steel tanks were erected, which featured diameters of varying dimensions. PERI UP scaffolding provided safe and comfortable working conditions for the complex welding and coating work.

For a long-lasting coating, the surfaces were not under any circumstances to be soiled or brought into contact with any foreign matter. Therefore, the scaffolding

construction was realised without anchors and pressure supports, and was also provided with temporary roofing. Due to its metric system grid, the PERI UP Flex modular scaffolding allowed bay lengths between 1.50 m and 3.00 m and bay widths of 0.75 m to 1.50 m to be combined with each other in 50-cm and 25-cm increments respectively. The adaptability provided by means of internal brackets and steel decking mounted in chessboard fashion meant that all working areas were optimally accessible and a high level of safety was ensured when the scaffolding was used.

In addition, it was especially advantageous that individual decks could be removed at any time and installed in another position. As a result, the scaffolding could be subsequently self-adapted for any unforeseen technical installation work – without complex scaffold assembly and whilst maintaining the high level of safety.



## Eemshaven Power Plant, Netherlands

High level of working safety for scaffold assembly and use

The 1,600-MW Eemshaven power plant is a highly efficient coal-fired power station complete with a switchable biomass combustion facility, and is equipped with the latest cleaning and filter technology. The two electric filters for flue gas desulphurisation are 64 m long and 35 m high respectively. For safely executed welding and insulation work in accordance with the highest quality standards, working platforms and access means were provided on the basis of the PERI UP Modular Scaffolding System. An externally-fitted working scaffold with integrated 75-cm flights of stairs was used for the final assembly of altogether

eight inlet ducts. The scaffold solution could be optimally adjusted in a metric grid arrangement to suit the cantilevered funnel shape of up to 4.50 m – in part, suspended from a gallows structure comprised of PERI UP system components. Assembly of the modular scaffolding was carried out extremely safely using the guardrail in advance. In addition, the PERI scaffolding solution took into account the existing steel structure as well as those walkways already mounted, and was easily adapted to the structural conditions.

Using the metric PERI UP grid system was a great advantage especially for

the spatial scaffolding assembly of the filter funnels: for optimum adaptation to the existing steel structure without requiring the assembly of a time-consuming tube-and-coupler construction. The scaffold bays could be divided horizontally and vertically as required; 300-cm scaffold bays in the area of the structural elements that were to be worked on, for example, were divided into three sections with widths of 75 cm, 150 cm and 75 cm – while the generous scaffolding bays of the lower sections minimised material usage and simultaneously improved accessibility.

## PERI UP Flex working platforms in use



### Dedusting System for Blast Furnace 9, ThyssenKrupp, Duisburg, Germany

PERI UP and VARIOKIT: 2 systems – 1 grid

ThyssenKrupp Steel Europe operates four company-owned blast furnaces at the Duisburg facility. For the extensive modernisation measures, Blast Furnace 9 was taken out of service and brought in line with the very latest technical standards. Part of the work included the re-insulation of the casting house dedusting system. For this, PERI scaffolding specialists planned a project-specific working scaffold which was based on two compatible modular construction systems: PERI UP and VARIOKIT. Both systems follow a uniform metric basic grid.

The PERI UP Flex Modular Scaffolding System provided optimal working conditions for all insulation work. The high degree of variability allowed any adjustments in 25-cm increments – resulting in completely safe working platforms. Through the consistent use of system scaffolding components, the decking areas were free of gaps and tripping hazards. Guardrails and toeboards could be installed end-to-end also without any gaps. Safe and quick access to all levels was provided by integrated stair towers complete with 75-cm-wide aluminium flights of stairs.

In order to access the plant sections to be worked on via the non-supporting flat roof, a girder grid for transferring loads was integrated into the PERI UP scaffolding solution at a height of 12 m – formed using rentable steel walers taken from the VARIOKIT Engineering Construction Kit. Due to the 12.5-cm grid system, the VARIOKIT could be ideally combined with PERI UP Rosett Flex. Standardised connecting means facilitated continuous installation with system components – without any time-consuming adjustment work with tubes and couplers.



### Northwest Redwater Project (NWR), Edmonton, Canada

Time and cost factor under control, safety levels increased

North-east of Edmonton/Alberta, the world's most modern oil sand refinery has been realised. The facility will produce 150,000 barrels per day, i.e. close to 2.5 million litres of oil. Since 2013, plant components have been installed on the 2-km<sup>2</sup> site, and the first of a total of three sections became operational in the autumn of 2017.

PERI's North American scaffolding specialists planned and supplied PERI UP industrial scaffold solutions, as well as ensuring the on-time availability of correspondingly large quantities of materials. 1,500 t of scaffolding equipment was in daily use, and around 1500 people worked on the construc-

tion site during peak times. Safety was always the top priority: one of the most important objectives for all project participants was to ensure that the estimated 1 million working hours did not involve any accidents.

For this, PERI UP provided system-integrated advantages during scaffold assembly and use. For example, due to the perfectly coordinated metric grid arrangement of the scaffolding components, plant sections could be systematically scaffolded in 25-cm increments without any on-site tube-coupler assembly, and thus created very safe working platforms. In addition, the detailed 3D scaffold planning with PERI

CAD on the jobsite allowed solutions to be approved in advance with all the project partners. As a result, all problem areas could be identified at an early stage and the working scaffold then optimised for further usage. Thereby, any improvisations during the actual scaffolding construction phase could be avoided. This accelerated working speeds and ensured a high level of safety.

**The optimal System  
for every Project and  
every Requirement**



**Wall Formwork**



**Column Formwork**



**Slab Formwork**



**Climbing Systems**



**Bridge Formwork**



**Tunnel Formwork**



**Shoring Systems**



**Construction Scaffold**



**Facade Scaffold**



**Industrial Scaffold**



**Access**



**Protection Scaffold**



**Safety Systems**



**System-Independent  
Accessories**



**Services**



**PERI GmbH**  
**Formwork Scaffolding Engineering**  
 Rudolf-Diesel-Strasse 19  
 89264 Weissenhorn  
 Germany  
 Tel. +49 (0)7309.950-0  
 Fax +49 (0)7309.951-0  
 info@peri.com  
 www.peri.com

